

# Modular Display System/**Centro 3**



---

## **CENTRO 3 - Modular Display System**

- Designed for simple magnetic fixing of your graphic panel
- Innovative modular display system
- Contemporary neon acrylic features
- Unique, robust anodised aluminium construction
- Requiring only a single hex bit for complete assembly
- 4mm hex key or power tool kit supplied
- Shaped silver base plate to maximise stability
- Overall height without lighting 2019mm
- Quality assured – 5 year guarantee

# Modular Display System/**Centro 3**

## Available in 3 widths

- Graphic widths - 750mm x1, 750mm x2 and 750mm x3



C3KS/75

C13KS/150

C3KS/225

## Specifications

### Centro 3 750mm x1 (C3KS/75)

- Weight with wheeled trolley case 31kg
- Maximum footprint 1226mm x 380mm

### Centro 3 750mm x2 (C3KS/150)

- Weight with 2 x wheeled trolley cases 53kg
- Maximum footprint 2269mm x 380mm

### Centro 3 750mm x3 (C3KS/225)

- Weight with 2 x wheeled trolley cases 65kg
- Maximum footprint 3312mm x 380mm

Overall height of all Centro kits is 2015mm.  
The above weight figures include the kit, wheeled trolley cases and packaging.

# Modular Display System/**Centro 3**

## Post caps available in various colours

- Range of coloured neon acrylic features - blue, green, red and standard frost



## **CENTRO** wheeled trolley case

- Compact and durable moulded plastic case and lid
- Base fitted with Rubber Wheels
- Moulded lid handle with additional side carry handle
- 3 lid latches with lockable facility
- White lined graphics tube 254mm dia. x 980mm (can hold 4 x 1990mm drops)
- Internal elasticated product retaining strap
- Overall case dimensions 520mmW x 440mmD x 1130mmH
- Net weight 9.0kg
- Quality assured - 12 months guarantee



## **POWER** tool kit

- Versatile Cordless Screwdriver with variable torque settings
- Kit contains 1x 4mm hex bit for complete Centro assembly
- 1x spare manual 4mm hex key for emergency use only
- 3.6v Lithium-ion battery
- Compact carry container 200mmW x 172mmH x 117mmD
- Net weight 1.2kg

Supplied with C2KC/150 and C2KC/225 as standard.



## **4mm Hex Key**

- High strength nylon handle
- Ergonomic handle for maximum grip and comfort

Supplied with C2KC/75 as standard.



# CENTRO 3 (750mm x1) Graphic Specification

1990mm x 750mm (x1)

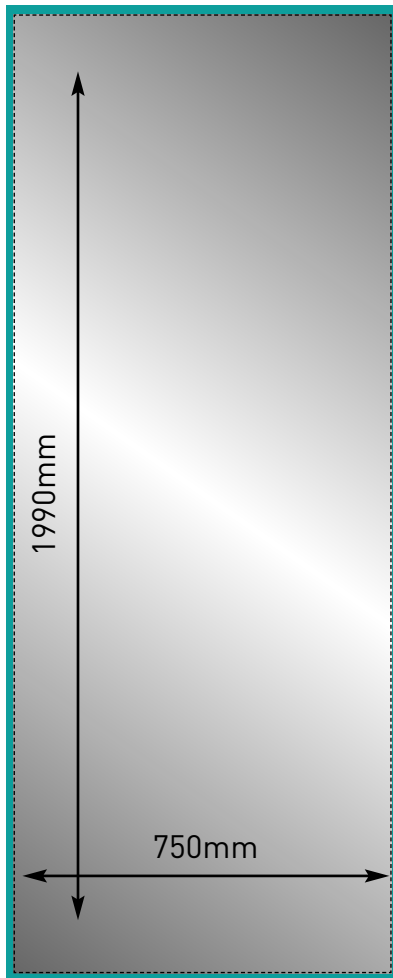
TOP



BOTTOM

-  Visible graphic area  
1990mmH x 750mmW (x1)
-  Finished print size  
1990mmH x 750mmW (x1)
-  Image bleed area  
2010mmH x 770mmW  
(10mm to all outer edges of the design)





# CENTRO 3 (750mm x2) Graphic Specification

1990mm x 750mm (x2)

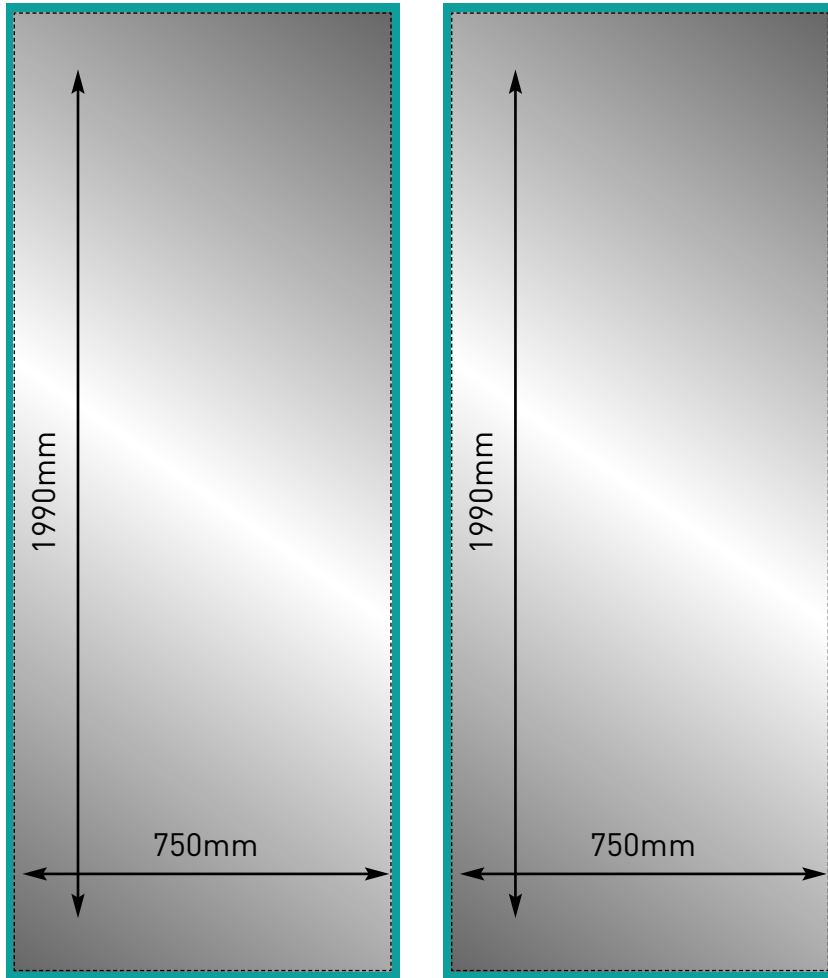
TOP



BOTTOM

-  Visible graphic area  
1990mmH x 750mmW (x2)
-  Finished print size  
1990mmH x 750mmW (x2)
-  Image bleed area  
2010mmH x 770mmW  
(10mm to all outer edges of the design)







# CENTRO 3 (750mm x3) Graphic Specification

1990mm x 750mm (x3)

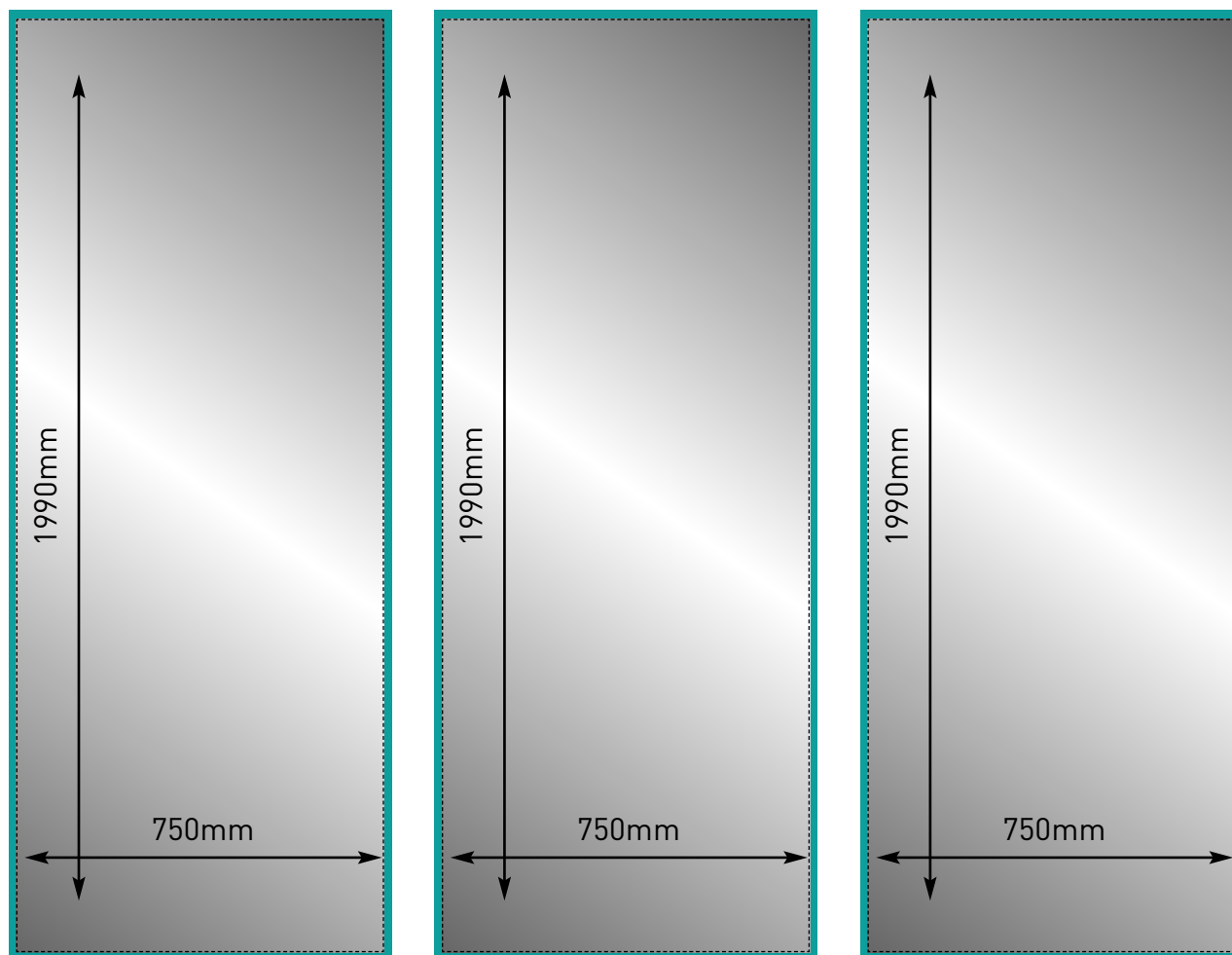
TOP



BOTTOM

-  Visible graphic area  
1990mmH x 750mmW (x3)
-  Finished print size  
1990mmH x 750mmW (x3)
-  Image bleed area  
2010mmH x 770mmW  
(10mm to all outer edges of the design)



# Centro 3 Assembly Instructions

(with spacer bars)



1

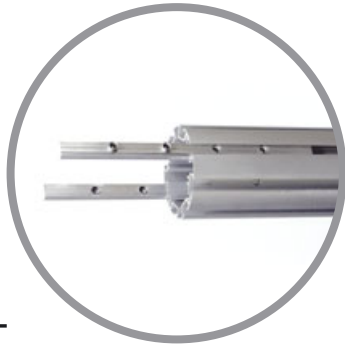

Stand base on the ground.  
Loosen grub screws and slide both connector bars half way out of groove and retighten.  
Repeat for other base posts.  
**Note:** Base plates pre-assembled on kits supplied in carry bag only.

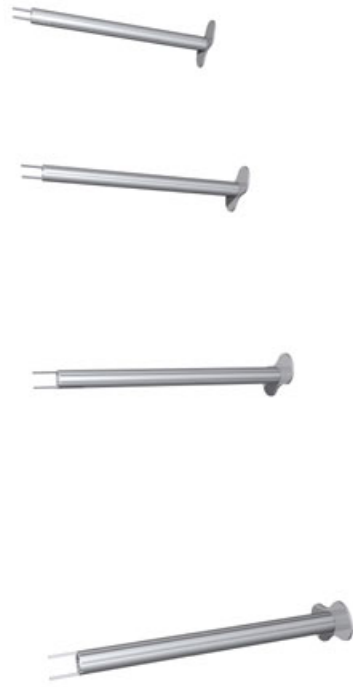

2

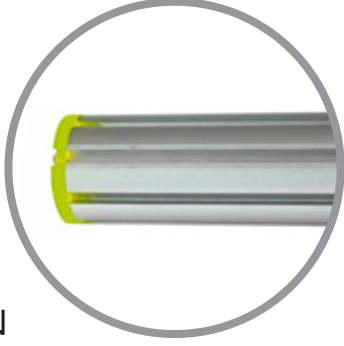

The upper 8-way post end cap has two notches which should align with the connector bar grooves shown in stage 3.

3

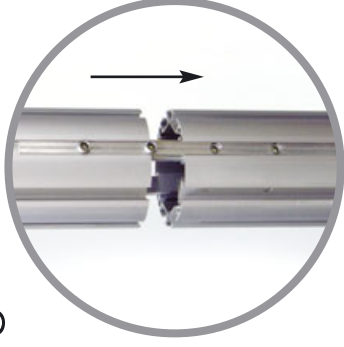

Join posts and tighten the grub screws to make assembly secure.  
Repeat for other base posts.





4



Slot spacer bars into assembled post approx 150mm from top and base. Tighten the grub screws to lock into place.

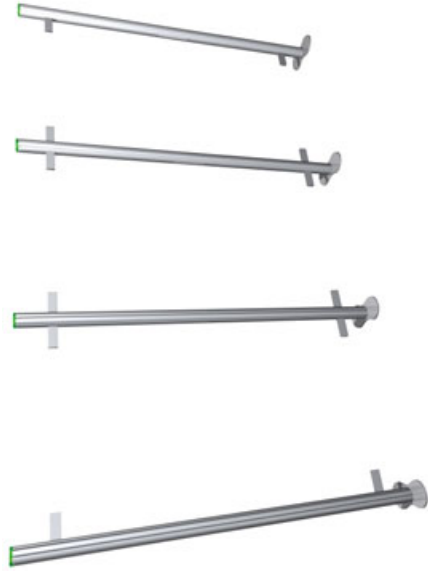

5



The side straight vertical graphic rails should now be assembled. Note position of graphic fixing strips, which should align.

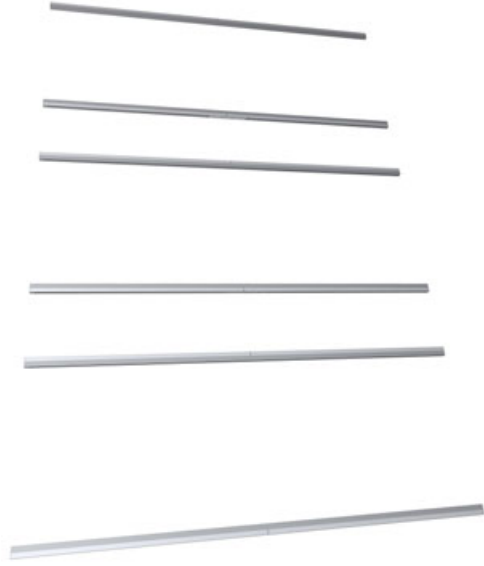

6



Slot vertical rails onto spacer bars leaving space at bottom for the horizontal graphic rail. Secure in place by tightening grub screws. Single strip line should be on the edge closest to post when viewed from front.



7



Connect first horizontal rails to vertical rails and tighten grub screws as before. Adjust height of vertical rails if necessary to ensure assembly is square.



8



Slot second horizontal rails onto all vertical rails and tighten grub screws.



9

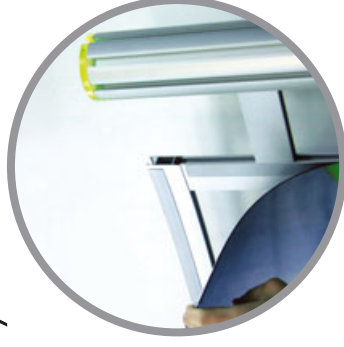

Affix graphic panels to the graphic fixing strips, starting from the top and side, working across the completed system.



# Centro 3 Assembly Instructions

(no spacer bars)



1

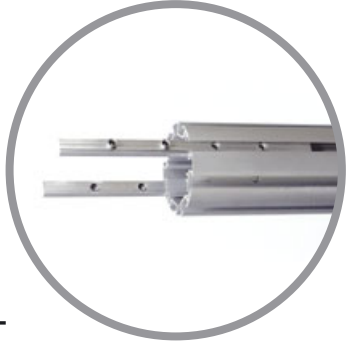

Stand base on the ground.  
Loosen grub screws and slide both connector bars half way out of groove and retighten.  
Repeat for other base posts.  
**Note:** Base plates pre-assembled on kits supplied in carry bag only.

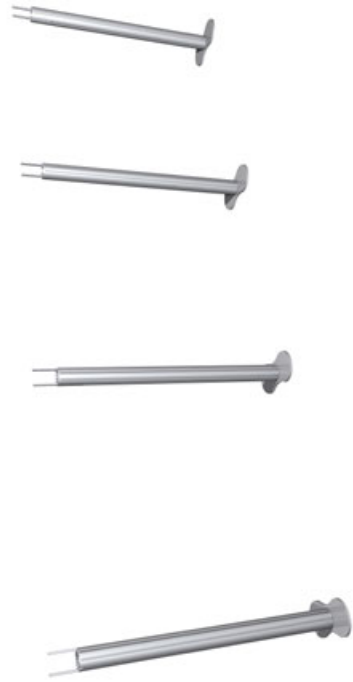

2

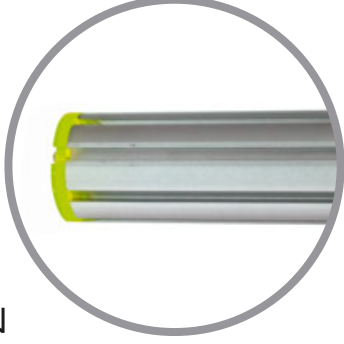

The upper 8-way post end cap has two notches which should align with the connector bar grooves shown in stage 3.



3

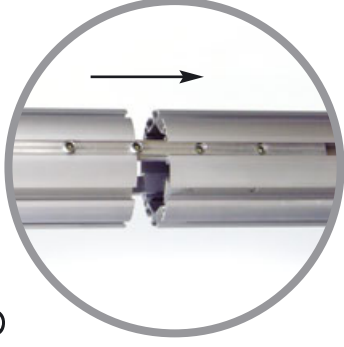

Join posts and tighten the grub screws to make assembly secure.  
Repeat for other base posts.



4

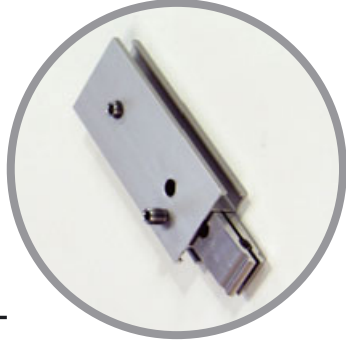

Remove four internal clamps from the spacer bars by removing grub screw and sliding out.

5



Insert internal clamps into both ends of the 750mm horizontal rails and secure by inserting grub screw and tightening (not fully).

6



Connect first horizontal rails at the bottom of posts, leaving a 10mm gap between underside of rail and surface of base plate. Tighten clamp screws to secure in place.

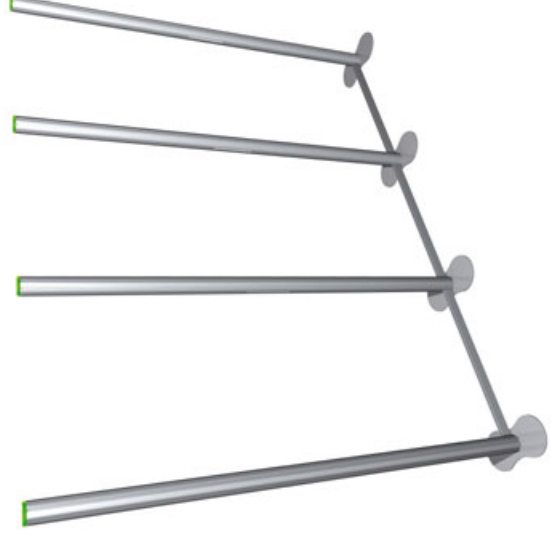

7

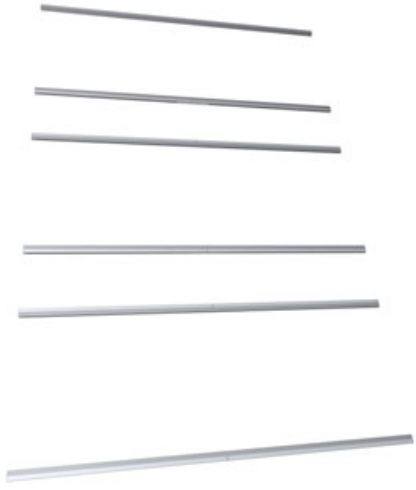

The side straight 950mm graphic rails should now be assembled. Note position of graphic fixing strips, which should align.

9



Slot second horizontal rails onto all vertical rails and fit clamps into 8-way post. Tighten clamp screws to secure assembly.



8



Connect assembled vertical rails to the bottom horizontal rail. Single strip line should be on the edge closest to the post when viewed from the front.



10

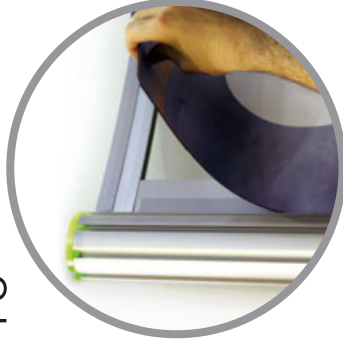

Affix graphic panels to the graphic fixing strips, starting from the top and side, working across the completed system.

